



# Remote Electrical Substation Control

*Pulsar Industry offers an innovative solution for electrical substation remote control of urban and suburban public transport networks.*

The electrical substations (often abbreviated SSE) form a network of electrical distribution nodes. They are usually located near power stations, in end user supply points or interconnection points between electrical line networks.

The substation houses a transformer system which is designed to decrease voltage rates, supply energy to catchment areas when needed or increase voltage to transmit energy when produced.

Electric power is transmitted at a high voltage rate to reduce leakages which according to Joule are proportional to the square of the current ( $P = R \cdot I^2$ ), in relationship to the current tension according to Ohm's law ( $V = R \cdot I$ ). When increasing tension, the current is decreased to the same resistance (power line transmission resistance remains unaltered) and as

a consequence leakages of electricity dispersed as heat are decreased: known as the Joule effect.

SSE play a fundamental role in electrically powered public transport such as railway trains and trams. Each electrical line has more than one adjacent substation according to their voltage rate and power download. The substations are usually fed by long distance three-phase 130 KV power lines.

Power substation supervisory and control is crucial to distributing energy, and due to its nature substations may be dislocated over a vast area to cover just one territory adequately.

In cases like this and to manage the different devices along with great quantities of analog and alarms, it is essential that the operators have centralized remote

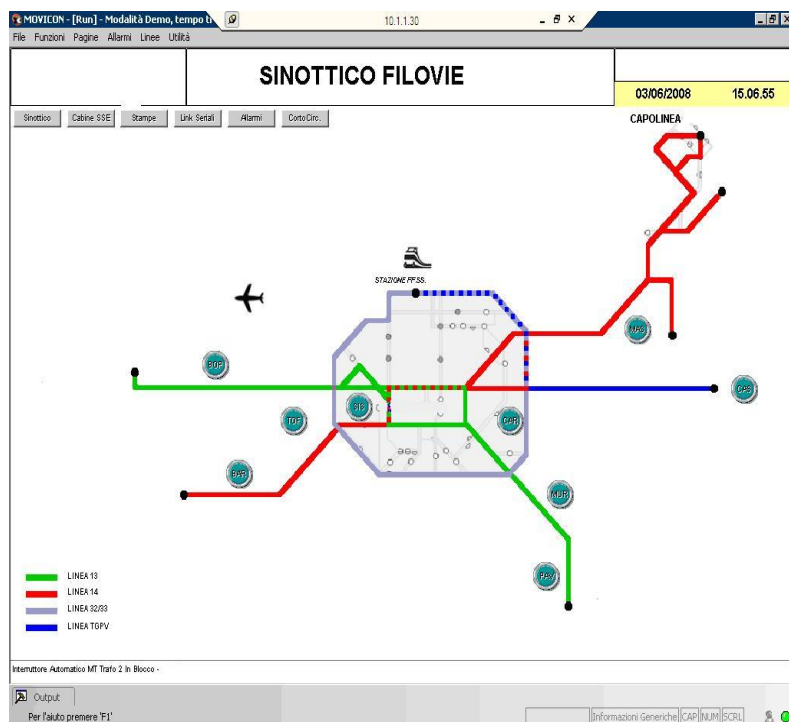

*The Remote control main screen.*

control systems capable of guaranteeing perfect electricity distribution efficiency.

Pulsar Industry Srl has designed and applied a solution, within this context, to a public transport company in one of the most important cities in Italy. Pulsar Industry Srl is a well established company in industrial engineering, with offices in Spilamberto (Modena, North Italy), and has been operating since the 80's in different industrial automation sectors. This company invests many of its resources in research and development. By constantly keeping updated on emerging and new technologies has made them highly capable of proposing innovation and advanced technological solutions.

By putting their client demands into perspective, Pulsar Industry then develops the project completely compliant to their clients' needs. Each phase is accomplished and specific - from the black board to the end result - entirely within the company which is fully equipped with technicians and specialists qualified in various sectors to follow each phase step-by-step until the desired end result is reached.

The public transport company which now uses this project provides urban services and suburban and extra-urban services in all over its regional territory (regional capital), one of the most widespread and populated regions in Italy. This transport company makes great efforts to be environmental friendly by constantly renewing its large fleet with vehicles that

cause less harm to the environment: hybrid or methane vehicles, widespread use of electric trams or trolley buses. A modern remote control system has just been setup and activated within this ambient to control all the electrical substations which feed electricity to the whole network of tramlines.

### The Remote Control Solution

The remote control system engineered by Pulsar Industry is based on one multi-modular platform, which allows the system to cater for any number of electric substations to power the tram network or trolley bus in any city. The substations are situated near the feeder lines and are connected to the central control station with special-purpose telephone lines. The supervision application designed by Pulsar Industry is based on the Movicon Scada/HMI technology working in the Windows Server 2003 environment. It has been designed for easy remote control connecting using the Movicon Web Client technology, which offers cost efficient management via the web, using the most commonly used internet browsers or mobile phones. Remote access to the system, insertable in a local geographical network, is only granted to authorized users enabled with all the necessary data transition security requirements. Thanks to this Web client solution, users can view and control the whole running of the network by using remote control and perform analysis on historically logged data and statistics.

### Control

Each SSE is controlled by locally distributed PLCs with the mission to manage all devices involved autonomously and to communicate with the supervision system, residing in the control centre station. A connection has been set up, dedicated to communication between local PLCs and the central supervision system. Both central and remote control have been entirely designed and realized by Pulsar Industry who also supplied the PLCs and programmed the automation logic of the entire system.

The complete network's electric feeders are monitored in realtime from the central supervision station to allow immediate intervention if any anomaly occurs. A screen has been configured for each SSE clearly showing the current status of every device housed within.

All the analogical electrical current, tension and active power values are recorded and can be displayed in historical Trends.

### Events recorded in chronological order

A program has been installed within the PLC to record events chronologically (RCE) with intuitivity. All the events of each SSE are recorded

every 10 milliseconds. Each event is recorded with the time and data of occurrence and transmitted to the supervision PC to save on a *relational database* table based on MS SQL Server.

The RCE permits users to quickly track down causes triggering problems: when a short circuit is alerted, the cause triggering the problem can be analysed by quickly clicking on the circuit breaker alerting the error from the sequence of the various circuit breakers opened in cascade mode on screen.

**Comand**

Operating commands can be sent from the Supervision terminal to all the devices, contained in each one of the SSEs, to isolate those which are faulty and activate others, evidently a great advantage in terms of worker safety where action is immediate to ensure end users are not left without electricity. Special purpose function scripts have been inserted in the application, designed with Movicon, to permit command sequence executions in complete automatic. This functionality

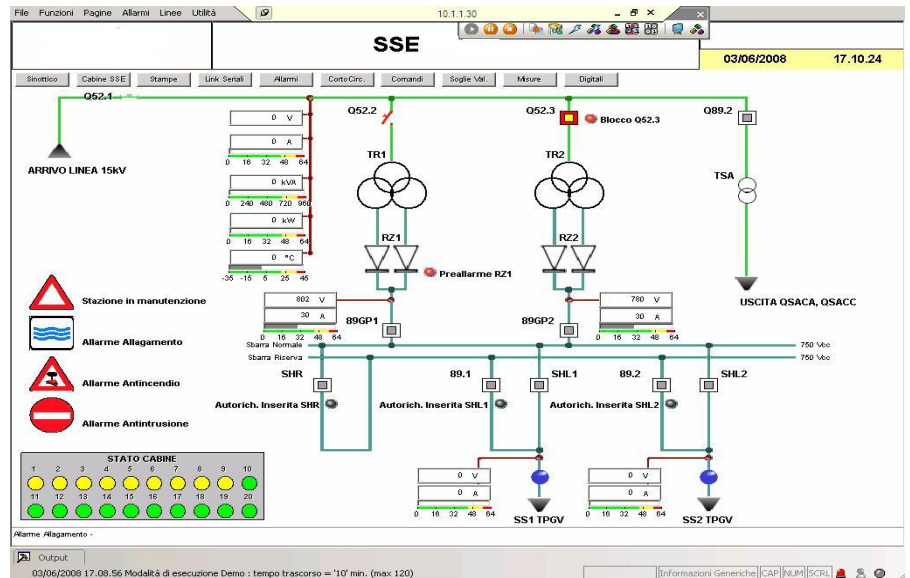

*One of the SSE electrical substation control panels designed by Pulsar with Movicon.*

activates the various SSEs at the beginning of each service circulation time and deactivates them when completed for system security purposes.

**Solution advantages**

With this proposal, Pulsar Industry offers a winning and very reliable solution to running electrical substations by remote control. Centralized control reduces manual worker resources to the minimum while maximizing and guaranteeing security all round at the same time. The remote control software engineered by Pulsar Industry is designed for logic controller integration to manage physical processes and record all event occurrences in the network. Thanks to the openness and modularity of Movicon, this system offers security and running cost effectiveness, securing quick investment returns.

REGISTRAZIONI RCE				
INPUT	DESCRIZIONE	VALORE	DATA - ORA	MILLISEC.
I227	Allarme Comunicazione AL 2	0	10/07/2008 17.30.57	830
I227	Allarme Comunicazione AL 2	1	10/07/2008 17.30.46	750
I002	Allarme Antintrusione	1	10/07/2008 17.30.17	20
I002	Allarme Antintrusione	0	10/07/2008 17.30.07	650
I002	Allarme Antintrusione	1	10/07/2008 17.27.28	830
I002	Allarme Antintrusione	0	10/07/2008 17.27.20	770
I227	Allarme Comunicazione AL 2	0	10/07/2008 17.25.24	500
I019	Interruttore Automatico MT Trafo 2 Aperto	0	10/07/2008 17.25.15	990
I020	Interruttore Automatico MT Trafo 2 Chiuso	0	10/07/2008 17.25.15	970
I022	Interruttore Automatico MT Trafo 2 In Blocco	1	10/07/2008 17.25.15	930
I227	Allarme Comunicazione AL 2	1	10/07/2008 17.25.13	430
I227	Allarme Comunicazione AL 2	0	10/07/2008 17.24.43	300
I227	Allarme Comunicazione AL 2	1	10/07/2008 17.23.26	210
I227	Allarme Comunicazione AL 2	0	10/07/2008 17.23.21	20
I227	Allarme Comunicazione AL 2	1	10/07/2008 17.23.15	450
I227	Allarme Comunicazione AL 2	0	10/07/2008 17.23.10	520
I227	Allarme Comunicazione AL 2	1	10/07/2008 17.22.20	940
I002	Allarme Antintrusione	1	10/07/2008 17.21.57	290
I002	Allarme Antintrusione	0	10/07/2008 17.21.43	110
I002	Allarme Antintrusione	1	10/07/2008 17.21.37	380
I002	Allarme Antintrusione	0	10/07/2008 17.21.26	660
I002	Allarme Antintrusione	1	10/07/2008 17.18.21	870

*A screen showing events recorded in chronological order. The PLC records events in chronological order which are then displayed in their exact sequence in the supervisor.*

Pulsar Industry Srl  
Ing. Lorenzo Grandi